

LOC		DIST		REVISIONS			
P	LTR	DESCRIPTION	DATE	DMN	APVD		
C		REV PER ECO 15-005923	4-22-15	CT	DM		

1. STAINLESS STEEL RETENTION CLIPS ARE INCLUDED IN INSERTS AT POSITIONS 1 THRU 15
2. POSITIONS 1 THRU 15 WILL ACCEPT SIZE 20 SOCKET CONTACT M39029/63-368 OR AMP PART NO 205090-1
3. UL/CSA DESIGNATION STAMPED IN THIS AREA, OPTIONAL
4. CONTACTS NOT SUPPLIED WITH CONNECTOR

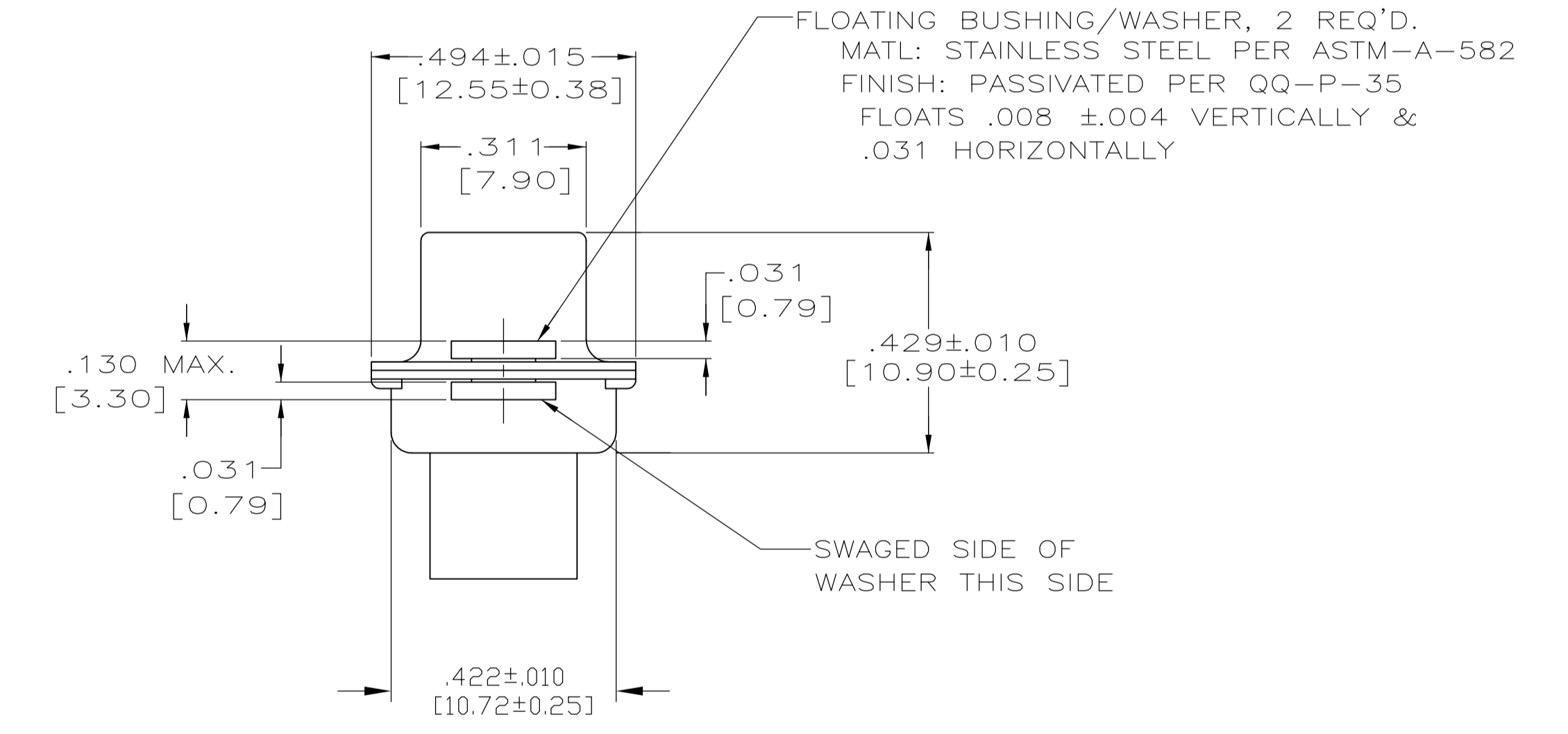
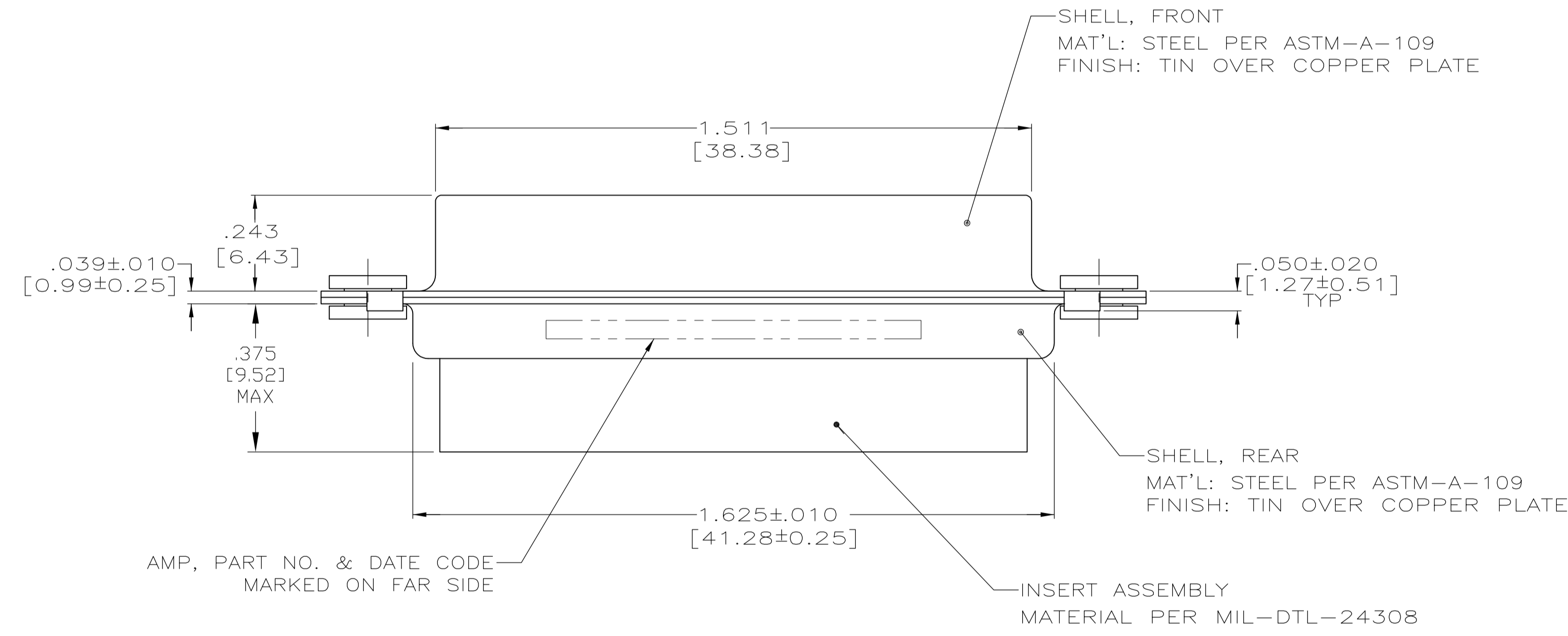
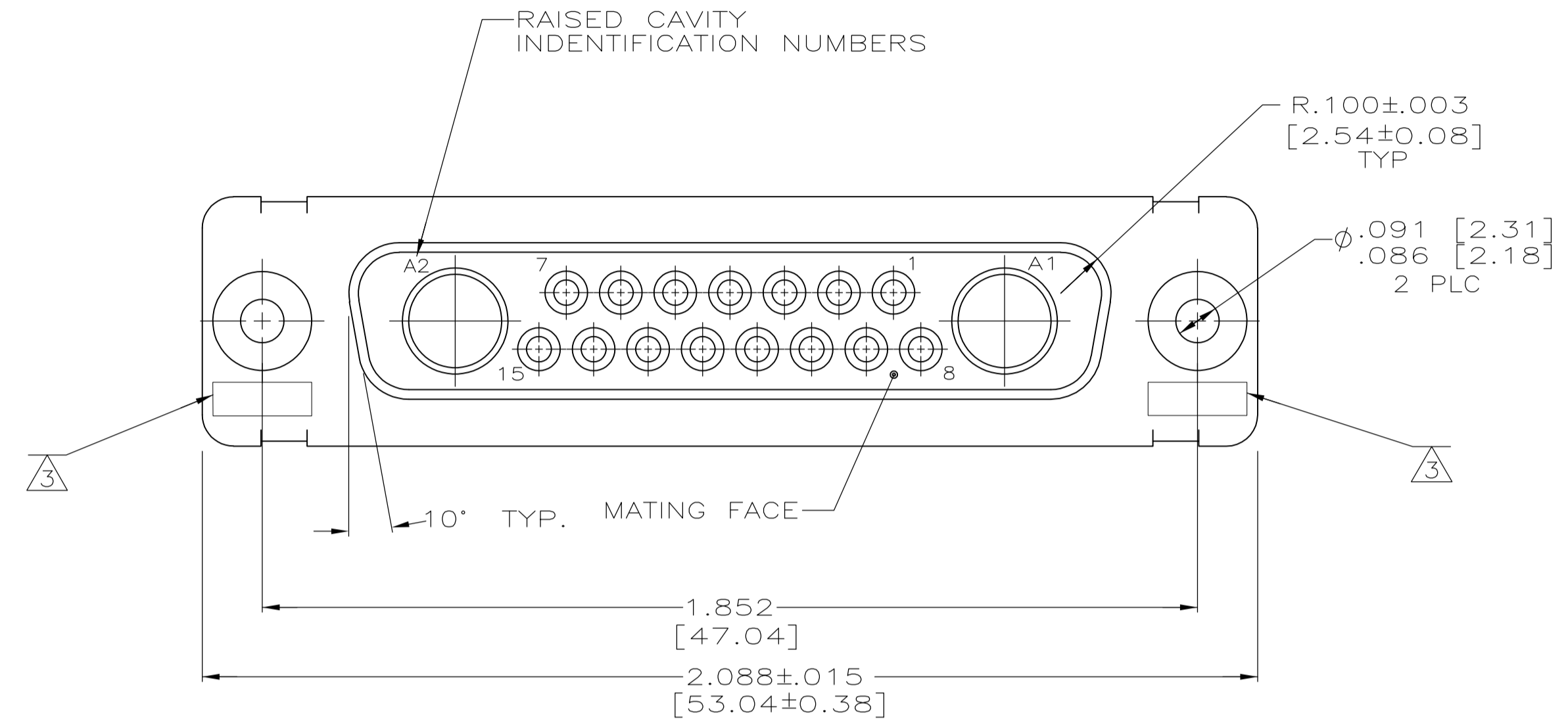

1663036-1
PART NO.

THIS DRAWING IS A CONTROLLED DOCUMENT.		DMN C.C.THOMAS 12SEP02	TE Connectivity	
DIMENSIONS: INCHES		CHK D.MILLER 12SEP02	NAME	
TOLERANCES UNLESS OTHERWISE SPECIFIED:		APPD D.MILLER 12SEP02	RCPT ASSY,17C2,COAX MIX SIZE 3,AMPLITE WITH FLOAT BUSHINGS	
0 PLC ± -	1 PLC ± -	PRODUCT SPEC	SIZE	CAGE CODE
2 PLC ± -	3 PLC ± -	APPLICATION SPEC	A1	00779
4 PLC ± -	ANGLES ± -	WEIGHT	1663036	RESTRICTED TO
MATERIAL SEE CALLOUTS	FINISH SEE CALLOUTS	CUSTOMER DRAWING	SCALE 4:1	SHEET 1 OF 1